

TANA

North America

From Waste to Value

Gx520 Landfill Compactor

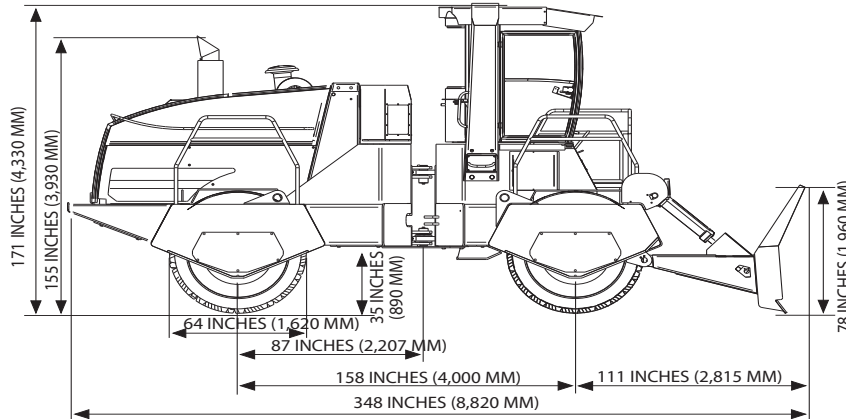

GENERAL INFORMATION

Weight	115,000-120,000 lbs (52K-54.4 kg)
Total length	348 in. (8,820 mm)
Total width	197 in. (5,000 mm)
Total height	171 in. (4,330 mm)
Wheel base	158 in. (4,000 mm)
Ground clearance	35 in. (890 mm)
Length without dozer blade	282 in. (7,140 mm)
Width without dozer blade	173 in. (4,380 mm)
Inside turning radius	133 in. (3,370 mm)
Driving speed range (low)	0-3 mph (0-5 km/h)
Driving speed range (high)	0-4.5 mph (0-7 km/h)
Maximum crushing force	57,327 lbs (255kN)

COMPACTION DRUMS

Uniform full width drums with forged solid steel crushing teeth. Adjustable scraper bars on both sides of the drums and adjustable steel wire cutters in the ends of drums.

Front / Rear Drum

Crushing/compaction width	150 in. / 150 in. (3.8 m/3.8 m)
Diameter with crushing teeth	64 in. / 64 in. (1.6 m)
Number of crushing teeth	110 pcs / 110 pcs
Height of crushing teeth	8 in. / 8 in. (200 mm)
Number of scraper bars	20 pcs / 20 pcs
Number of wire cutters	2 pcs / 4 pcs

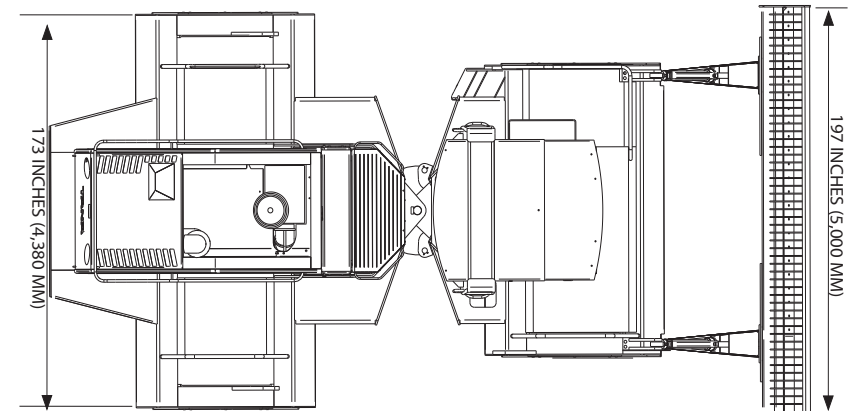

DOZER BLADE

The dozer blade is operated with two hydraulic cylinders.

- Two arms
- Width 197 in. (5,000 mm)
- Height 78 in. (1,960 mm)
- Movement above ground level 48 in. (1,200 mm)
- Movement below ground level 5 in. (115 mm)
- Upper part of blade: trash screen
- Bolt-on reversible cutting edges
- Arm joints equipped with hardened pins and spherical bearings

ENGINE

Cummins QSX15 – C535

- Turbo charged, 6 cylinders in line, after-cooled electrically controlled diesel engine that communicates with the TCS system
- Fulfills 2005 EPA & CARB Tier 3 and EC Stage 3A non-road emission certificates
- Maximum power: 589 hp (439 kW)/1,800 rpm
- Power rating: 535 hp (399 kW)/2,100 rpm, DIN 6271 (SAEJ 1995)
- Maximum torque: 1,873 lb-ft (2,539 Nm)/1,400 rpm

Engine equipment

- Dry type air cleaner with replaceable primary and safety element
- Built-in pre-cleaner and service indicator
- 1 piece fuel filter and water separator
- 1 piece oil filter
- Exhaust muffler
- Radiator with separate charge air cooler
- Starter motor 24V
- Alternator 24V, 70A

CABIN AND CONTROLS

Equipment

- Pressurized, heat and sound insulated cabin with lights
- Insulation materials in accordance with ISO 3795
- Mechanically suspended adj. seat with built-in controls and seat belt. Optional swivel seat (140 degrees)
- Laminated safety glass windows
- Socket for mobile phone charger
- Front and rear windshield intermittent wipers and washers
- Heater and A/C unit
- Radio/CD player (AM/FM)
- Emergency exit, lockable door, shelf and lockers, external rear-view mirrors
- Replaceable cabin air filters
 - Pre-filter grade EU3, micro filter grade EU7, grade EU14
 - Active carbon filter mat (option)

Gauges included in TANA Control System (TCS)

- Engine oil pressure, engine coolant, engine intake manifold, fuel, engine oil and hydraulic oil temperature
- Final drive planetary temperature
- Fuel level, total fuel consumption
- Voltage, tachometer, boost pressure, engine working hours
- Engine load rate

System warnings in TCS

(indicator light, audible warning and alarm log)

- Engine air filter contamination
- Hydraulic oil temperature (both high and low)
- Low hydraulic oil level and fuel level
- High hydraulic oil contamination
- Planetary final drive temperature (both high and low)
- Hydraulic oil return line filter contamination
- Charge pressure filter contamination
- Low charge pressure
- Voltage (both high and low)
- 95 additional alarms

Controls

- Driving speed range selection
- Transmission on/off and parking brake
- Emergency shut down
- Ignition switch: power on/off and starting
- Heater and air conditioning unit, cabin temperature control

Control levers (joy-sticks)

Control levers will return to neutral position automatically when released and all related movements will stop.

- Left hand lever: controls driving speed and direction
- Right hand lever: controls steering, dozer blade and horn

TANA Gx SERIES

LANDFILL COMPACTOR CRUSHING FORCE

SERVICE PLATFORMS & PROTECTION

Service platforms and steps are equipped with handrails and non-slip safety surfaces. Engine housing is protected with lockable hoods. Gas spring cylinders assist in opening the hood. Hood acts as a service platform when opened.

VANDALISM PROTECTION

- Lockable cabin, engine compartment and fuel cap
- Key for ignition

ROPS / FOPS

Integrated in cabin structure

- ROPS in accordance with ISO 3471/1 and SAEJ1040C
- FOPS in accordance with ISO 3449 and SAEJ231

FRAME

The frame is constructed of two modular drum frames connected together with a longitudinal upper frame. The drum frame acts as a shell around the drum, which helps to prevent waste from rising into the upper parts of the machine.

The upper frame is equipped with center point articulation operated with two hydraulic cylinders.

- Articulation links are equipped with hardened pins and spherical steel bearings
- Angle of articulation: right 40 degrees; left 40 degrees

TANA PROTRACK

- Wireless GPRS-based connection to the TANA Control System
- Offers on-line information
- Monthly operational reports
- TANA ProLoc GPS compaction measuring system (optional)

TANA

North America

From Waste to Value

**FROM
WASTE
TO
VALUE**